

🇮🇹 ROTATORI IDRAULICI

🇬🇧 HYDRAULIC ROTATORS

🇫🇷 ROTATORS HYDRAULIQUES

🇩🇪 HYDRAULISCHE DREHMOTOREN

🇪🇸 ROTORES HIDRÁULICOS

MODELLO • MODEL MODÈLE • MODELL		R 1G	R 4G	R 3	R 3B	R 3C
PORTATA MAX • MAX AXIAL LOAD CHARGE MAXI • MAX AXIALBELASTUNG	t	5	8	5	8	15
PESO • WEIGHT POIDS • GEWICHT	Kg	100	220	93	153	252
ROTAZIONE • ROTATION ROTATION • DREHBEREICH		Cont.	Cont.	Cont.	Cont.	Cont.
COPPIA MAX • MAX TORQUE COUPLE MAXI • MAX DREHMOMENT	daNm	185	380	120	240	240
PRESS. MAX ROT. • MAX ROTAT. PRESS. PRESS MAX ROTAT. • P. MAX DREHMOTOR	bar	110	170	200	200	200
PRESS. MAX ATT. • MAX GRAB PRESS. PRESS MAX EQUIP. • P. MAX GREIFER	bar	300	300	300	300	300
CILINDRATA • OIL FLOW VOLUME CYLINDREE • SCHLUCKVOLUMEN	cm³/g	1360	1630	500	1000	1000
DIMENSIONI SIZES DIMENSIONS ABMESSUNGEN	A	340	420	250	284	305
	B	148	150	120	150	150
	C	50	70	50	70	70
	E	-	-	246	290	312

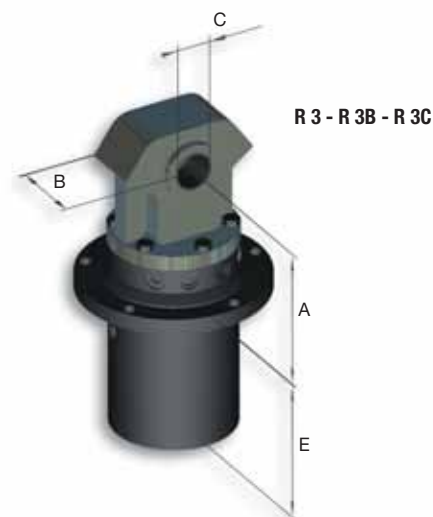
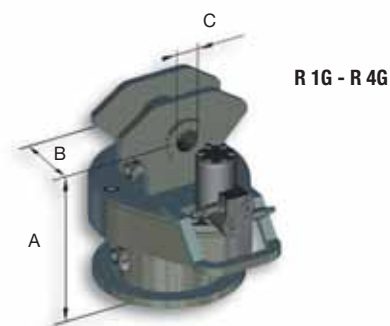

🇮🇹 GIUNTI IDRAULICI

🇬🇧 HYDRAULIC JOINTS

🇫🇷 JOINTS HYDRAULIQUES

🇩🇪 HYDRAULISCHE DREHDURCHFÜHRUNGEN

🇪🇸 JUNTAS HIDRÁULICAS

MODELLO • MODEL MODÈLE • MODELL		R 2	R 2A	R 2B	R 2C
PORTATA MAX • MAX AXIAL LOAD CHARGE MAXI • MAX AXIALBELASTUNG	t	6	8	8	15
PESO • WEIGHT POIDS • GEWICHT	Kg	71	114	126	224
PRESS. MAX ATT. • MAX GRAB PRESS. PRESS MAX EQUIP. • P. MAX GREIFER	bar	300	300	300	300
DIMENSIONI SIZES DIMENSIONS ABMESSUNGEN	A	400	461	284	504
	B	118	118	150	150
	C	50	50	70	70
	E	110	125	193	215
	F	36	45	-	-

