

 **BENNE A POLIPO ELETTROIDRAULICHE PER SIDERURGIA E SCARICO PORTUALE**  
 **ELECTROHYDRAULIC GRABS FOR THE METALLURGY AND THE DOCK SIDE DISCHARGE**  
 **GRAPPINS ÉLECTRO-HYDRAULIQUES POUR SIDÉRURGIE ET DÉCHARGEMENT PORTUAIRE**  
 **ELEKTROHYDRAULISCHE MEHRSCALENGREIFER FÜR DIE EISENMETALLURGIE UND DIE HAFENABLADUNG**

MODELLO MODEL MODÈLE MODELL	CAPACITÀ CAPACITY CAPACITÉ INHALT m³	PESO WEIGHT POIDS GEWICHT Kg	DENTI TEETH DENTS ZÄHNE N.	MOTORE MOTOR MOTEUR MOTOR KW	PRESS. PRESS. DRUCK bar	FORZA AL DENTE TINE FORCE PUISS. À LA DENT SCHLISSKR. JE SCHALE Kg	TEMPI • TIMES TEMPS • ZEITE		DIMENSIONI • SIZES DIMENSIONS • ABMESSUNGEN				
							AP. • OP. OUV. • OEF sec.	CH. • CL. FERM. • SCHL. sec.	A	B	C	D	E
<b>ER 800</b>	0.8	2100	6	15	180	2200	7.5	11.5	2100	1450	2300	2000	1790
<b>ER 1000</b>	1	3350	8	22	180	2650	8	14	2400	1700	2650	2500	2150
<b>ER 1500</b>	1.5	3700	8	22	180	2330	8	14	2800	1800	2950	2700	2200
<b>ER 2000</b>	2.2	4000	8	22	180	1930	8	14	3250	2200	3500	2900	2250
<b>ER 3000</b>	3	7300	8	37	180	2800	9.5	15	3700	2460	4000	3380	2740
<b>ER 4000</b>	4	8700	9	45	180	3500	9.5	16	4100	2730	4490	3620	2830
<b>ER 5000</b>	5	9500	9	45	180	3250	9.5	16	4400	2800	4730	3770	2870

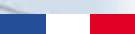
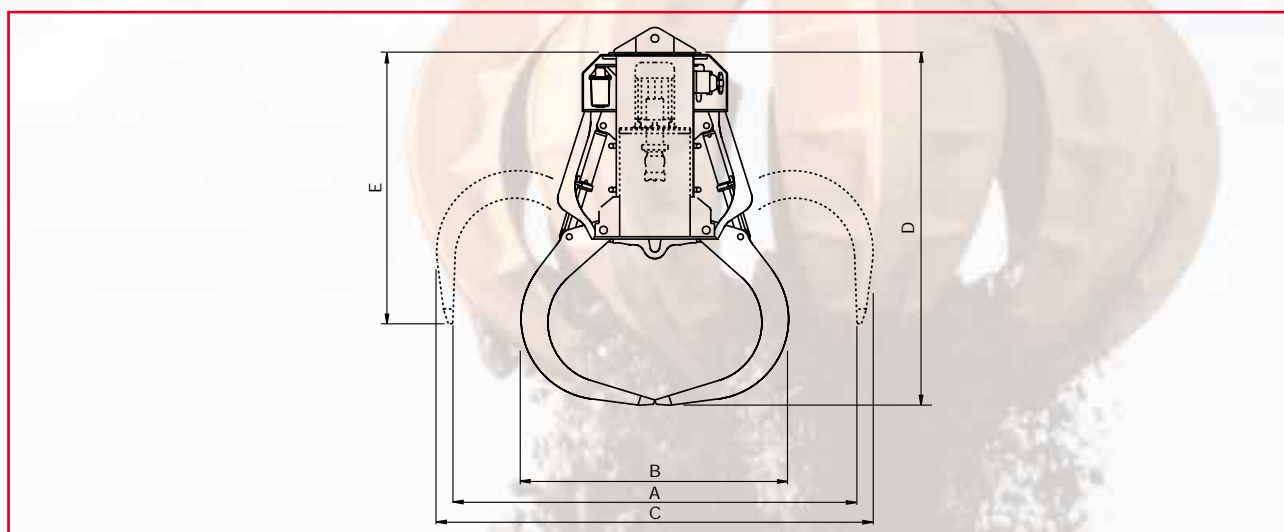

**Rozzi** S.p.A.